

UNI-ROYAL
厚聲集團

DATA SHEET

Product Name Carbon Film Fixed Resistors

Part Name CFR/CPR Series

File No. DIP-SP-001

1. Scope

- 1.1 This datasheet is the characteristics of Carbon Film Fixed Resistors manufactured by UNI-ROYAL.
- 1.2 High quality performance ; Great economy.
- 1.3 Flame Retardant available ; Automatically insertable .

2. Part No. System

The standard Part No. includes 14 digits with the following explanation:

2.1 1th~4th digits

This is to indicate the Coated type. Example: CFR0= Carbon Film Fixed Resistors ;CPR0= Carbon Film Power Resistors

2.2 5th~6th digits:

2.2.1 This is to indicate the wattage or power rating. To dieting the size and the numbers,

The following codes are used; and please refer to the following chart for detail:

W=Normal Size; 1~“G”to denote“1”~“16”as Hexadecimal:

1/16W~1W: (<1W)

Wattage	1/2	1/3	1/4	1/5	1/6	1/8	1/10	1/16
Normal Size	W2	W3	W4	W5	W6	W8	WA	WG
Small Size	S2	S3	S4	S5	S6	S8	SA	SG
Extra Small Size	U2	U3	U4	U5	U6	U8	UA	UG

1W~16W (≥1W)

Wattage	1	2	3	5	7	8	9	10	15
Normal Size	1W	2W	3W	5W	7W	8W	9W	AW	FW
Small Size	1S	2S	3S	5S	7S	8S	9S	AS	FS
Extra Small Size	1U	2U	3U	5U	7U	8U	9U	AU	FU

- 2.2.2 For power rating less than 1 watt, the 5th digit will be the letters “W”, “S” or “U” to represent the size required & the 6th digit will be a number or a letter code. Example: WA=1/10W; W4=1/4W;S2=1/2WS
- 2.2.3 For power rating greater or equal to 1 watt, the 5th digit will be a number or a letter code to represent the size required & the 6th digit will be the letters “W”, “S” or “U”. Example: 2W=2W; 2S=2WS;
- 2.3 The 7th digit is to denote the Resistance Tolerance. The following letter code is to be used for indicating the standard Resistance Tolerance. G=±2% J=±5% K= ±10%
- 2.4 The 8th to 11th digits is to denote the Resistance Value.
 - 2.4.1 If value belongs to standard value of E-24 series, the 8th code is zero, 9th~10th codes are the significant figures of resistance value, and the 11th code is the power of ten.
 - 2.4.2 If value belongs to standard value of E-96 series, the 8th~10th codes are the significant figures of resistance value, and the 11th code is the power of ten.
 - 2.4.3 The following number s and the letter codes are to be used to indicate the number of zeros in the 11th digit:
0=10⁰ 1=10¹ 2=10² 3=10³ 4=10⁴ 5=10⁵ 6=10⁶ J=10⁻¹ K=10⁻² L=10⁻³ M=10⁻⁴
- 2.5 The 12th, 13th & 14th digits.
 - 2.5.1 The 12th digit is to denote the Packaging Type with the following codes:
A=Tape/Box; T=Tape/Reel; B=Bulk/Box
 - 2.5.2 The 13th digit is normally to indicate the Packing Quantity of Tape/Reel packaging types. The following letter code is to be used for some packing quantities:
4=4000pcs 5=5000pcs C=10000pcs D=20000pcs E=15000pcs
 - 2.5.3 For some items, the 14th digit alone can use to denote special features of additional information with the following codes:
0=NIL P=Panaset type 1=Avisert type 1 2=Avisert type 2 3=Avisert type 3
4=PT-60mm 6=PT-62mm 7=Lead wire(H)38mm 8=PT-58mm 9=PT-64mm
A=PT-83mm B=PT-52mm C=PT-73mm D=PT-71mm

3. Ordering Procedure

(Example: CFR 2W ±5% 100Ω T/B-500)

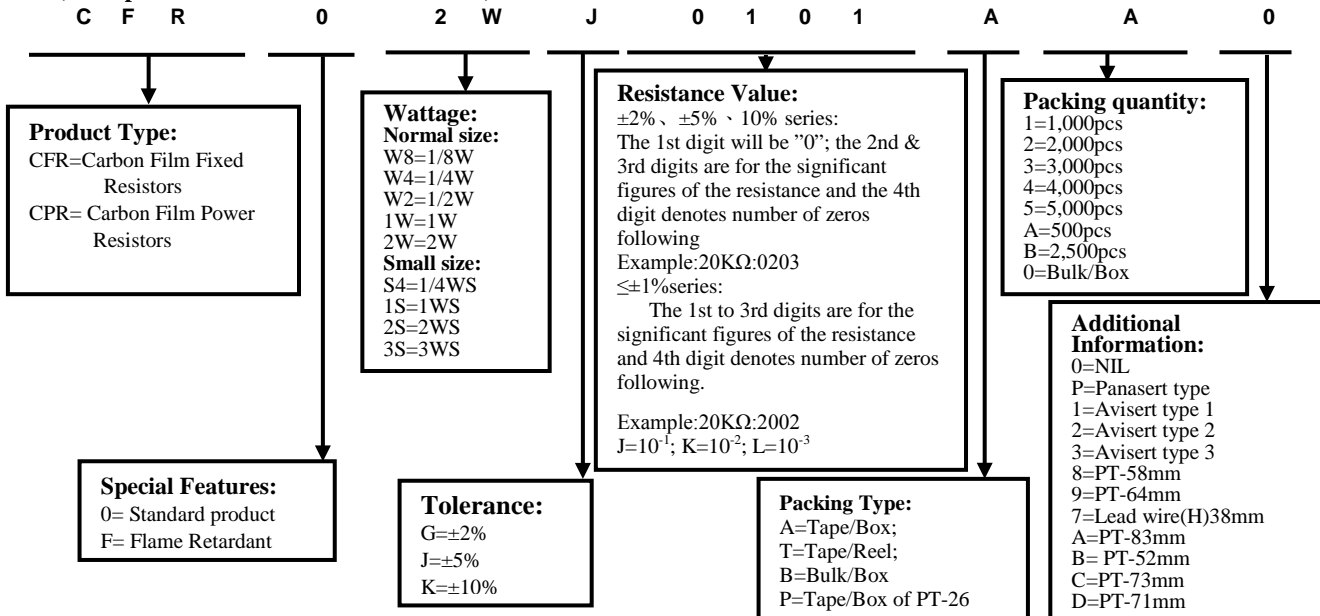

4. Marking

Resistors shall be marked with color coding
Colors shall be in accordance with JIS C 0802

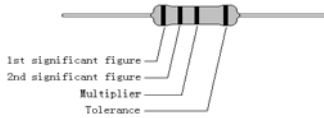
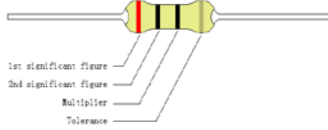

4.1 Label:

Label shall be marked with following items:

- (1) Type and style
- (2) Nominal resistance
- (3) Resistance tolerance
- (4) Quantity
- (5) Lot number
- (6) PPM

Example:

CARBON FILM FIXED RESISTORS	
WATT: 2W	VAL: 100Ω
Q'TY: 500	TOL: 5%
LOT: 4021548	PPM:

5. Dimension

For 1/8W、1/4WS :

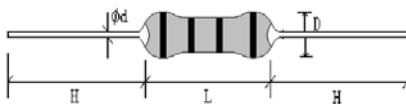

Other:

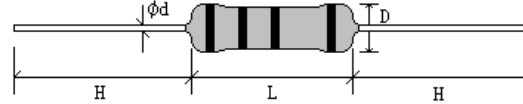

5.1 Ordinary Products:

Type	Dimension(mm)					Max Working Voltage	Max Overload Voltage	Dielectric Withstanding Voltage	Resistance Range	Tolerance
	D	L	d ±0.05	H ±3	PT					
CFR1/8W	1.9±0.3	3.3±0.3	0.45	28	52	200V	400V	400V	1Ω~1MΩ	±2% ±5% ±10%
CFR 1/4WS	1.9±0.3	3.3±0.3	0.45	28	52	200V	400V	400V	1Ω~1MΩ	
CFR 1/4W	2.2±0.3	6.5±1.0	0.54	28	52	250V	500V	500V	1Ω~10MΩ	
CFR 1/2W	3.0±0.6	9.5±1.0	0.54	28	52	350V	700V	700V	1Ω~10MΩ	
CFR 1WS	4.5±0.6	11.5±1.0	0.70	25	52	500V	1000V	1000V	1Ω~10MΩ	
CFR 1W	5.0±0.6	15.5±1.0	0.70	28	64	500V	1000V	1000V	1Ω~10MΩ	
CFR 2WS	5.0±0.6	15.5±1.0	0.70	28	64	500V	1000V	1000V	1Ω~10MΩ	
CFR 2W	6.0±0.6	17.5±1.0	0.75	28	64	500V	1000V	1000V	1Ω~10MΩ	
CFR 3WS	6.0±0.6	17.5±1.0	0.75	28	64	500V	1000V	1000V	1Ω~10MΩ	

5.2 High Power Products:

Type	Dimension(mm)					Max Working Voltage	Max Overload Voltage	Dielectric Withstanding Voltage	Resistance Range	Tolerance
	D	L	d ±0.05	H ±3	PT					
CPR1/2W	2.2±0.5	6.5±1.0	0.54	28	52	300V	500V	700V	3Ω~10MΩ	±2%
CPR 1W	3.5±0.5	9.5±1.0	0.54	28	52	500V	700V	1000V	3Ω~10MΩ	±5%
CPR 2W	4.5±0.5	11.0±1.0	0.70	25	52	500V	1000V	1000V	3Ω~10MΩ	±10%

6. Structure

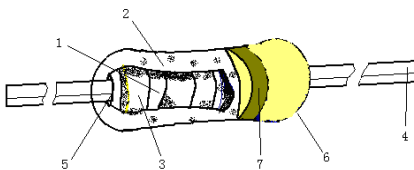

No.	Name	Material
1	Basic Body	Rod Type Ceramics
2	Resistor	Carbon Film
3	End Cap	Cold steel plated with copper/tin
4	Lead Wire	Tin solder coated copper wire
5	Joint	By welding
6	Coating	By welding (1). Celluloid paint (2). Insulated Resin Color: Beige(Standard) Light Brown(CFR1WS, CFR2WS, CFR3WS) Gray Green(CPR1/2W, CPR1W, CPR2W)
7	Color Code	Epoxy resin

7. Derating Curve

Power rating will change based on continuous load at ambient temperature from -55 to 155°C. It is constant between -55 to 70°C, and derate to zero when temperature rise from 70 to 155°C.

Voltage rating:

Resistors shall have a rated direct-current (DC) continuous working voltage or an approximate sine-wave root-mean-square (RMS) alternating-current (AC) continuous working voltage at commercial-line frequency and waveform corresponding to the power rating, as determined from the following formula:

$$RCWV = \sqrt{P \times R}$$

Remark: RCWV: Rating Continuous Working Voltage (Volt.) P: power rating (Watt) R: nominal resistance (Ω)

In no case shall the rated DC or RMS AC continuous working voltage be greater than the applicable maximum value.

The overload voltage is 2.5 times RCWV or Max. Overload voltage whichever is lower.

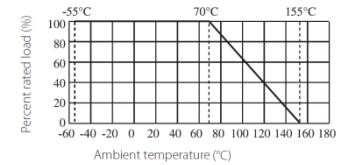

8. Performance Specification

Characteristic	Limits	Test Methods (GB/T5729&JIS-C-5201&IEC60115-1)
Temperature Coefficient	≤10Ω: ±300 PPM/°C 11Ω~99KΩ: ±450 PPM/°C 100KΩ~1MΩ: 0~700 PPM/°C 1.1MΩ~10MΩ: 0~1500 PPM/°C	4.8 Natural resistance changes per temp. Degree centigrade $\frac{R_2 - R_1}{R_1(t_2 - t_1)} \times 10^6 \text{ (PPM/°C)}$ R ₁ : Resistance Value at room temperature (t ₁); R ₂ : Resistance at test temperature (t ₂) t ₁ : +25°C or specified room temperature t ₂ : Test temperature (-55°C or 125°C)
Short-time overload	CFR: ΔR/R ≤ ±(1%+0.05Ω) CPR: ΔR/R ≤ ±(0.75%+0.05Ω)	4.13 Permanent resistance change after the application of a potential of 2.5 times RCWV for 5 seconds.
Insulation resistance	≥ 10,000 MΩ	4.6 If insulation withstanding voltage is <500V, test voltage equals insulation withstanding voltage; if the insulation withstanding voltage is ≥ 500V, test voltage will be 500±50VDC; test the resistance value after 1 minute.
Terminal strength	No evidence of mechanical damage	4.16 Direct load: Resistance to a 2.5 Kg direct load for 10 seconds in the direction of the longitudinal axis of the terminal leads. Twist test: Terminal leads shall be bent through 90° at a point of about 6mm from the body of the resistor and shall be rotated through 360° about the original axis of the bent terminal in alternating direction for a total of 3 rotations.
Resistance to soldering heat	ΔR/R ≤ ±(1%+0.05 Ω) with no evidence of mechanical damage	4.18 permanent resistance change when leads immersed to a point 2.0-2.5mm from the body in 260°C±5°C solder for 10±1 seconds.
Solderability	Coverage must be over 95%.	4.17 The area covered with a new, smooth, clean, shiny and continuous surface free from concentrated pinholes. Test temp. Of solder: 245°C±3°C Dwell time in solder 2~3 seconds.
Resistance to solvent	No deterioration of protective coatings & markings	4.29 Specimens shall be immersed in a bath of IPA completely for a 5±0.5 minutes using ultrasonic test equipment
Rapid change of temperature	ΔR/R ≤ ±(1%+0.05 Ω) with no evidence of mechanical damage	4.19 30 min at -55 °C and 30 min at 155°C; 100 cycles.
Load life in humidity	Normal type: ΔR/R ±3% for <100KΩ ±5% for ≥ 100KΩ Flame retardant type: ΔR/R ±5% for <100KΩ; ±10% for ≥100KΩ; High Power Products : ΔR/R ±(3%+0.05Ω)	7.9 Resistance change after 1,000 hours (1.5 hours "ON", 0.5 hour "OFF") at RCWV in a humidity test chamber controlled at 40°C±2 °C and 90 to 95% relative humidity.

<p>Load life</p>	<p>Normal type: $\Delta R/R \pm 2\%$ for $< 56K\Omega$ $\pm 3\%$ for $\geq 56K\Omega$ Flame retardant type: $\Delta R/R \pm 5\%$ for $< 100K\Omega$; $\pm 10\%$ for $\geq 100K\Omega$; High Power Products : $\Delta R/R \pm (3\% + 0.05\Omega)$</p>	<p>4.25.1 Permanent resistance change after 1,000 hours operating at RCWW with duty cycle of 1.5 hours "ON", 0.5 hour "OFF" at $70^\circ C \pm 2^\circ C$ ambient.</p>
<p>Low Temperature Storage</p>	<p>Normal type: $\Delta R/R \pm 2\%$ for $< 56K\Omega$ $\pm 3\%$ for $\geq 56K\Omega$ Flame retardant type: $\Delta R/R \pm 5\%$ for $< 100K\Omega$; $\pm 10\%$ for $\geq 100K\Omega$; High Power Products : $\Delta R/R \pm (3\% + 0.05\Omega)$</p>	<p>IEC 60068-2-1 (Aa) Lower limit temperature , for 2H.</p>
<p>High Temperature Exposure</p>	<p>Normal type: $\Delta R/R \pm 2\%$ for $< 56K\Omega$ $\pm 3\%$ for $\geq 56K\Omega$ Flame retardant type: $\Delta R/R \pm 5\%$ for $< 100K\Omega$; $\pm 10\%$ for $\geq 100K\Omega$; High Power Products : $\Delta R/R \pm (3\% + 0.05\Omega)$</p>	<p>MIL-STD-202 108A Upper limit temperature , for 16H.</p>

9. Packing

9.1 Tapes in Box Packing:

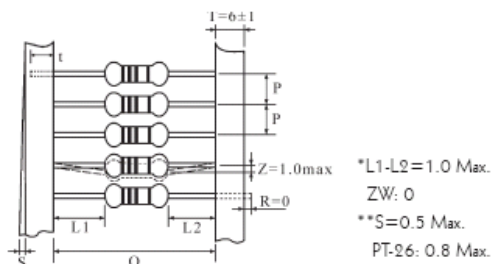
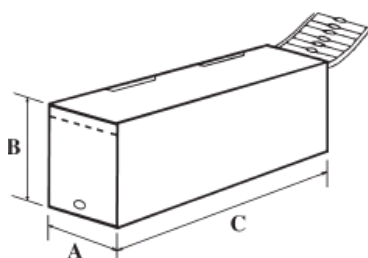

Dimension of T/B (mm)

Type	O	P	W (A) ± 5	H (B) ± 5	L (C) ± 5	Quantity Per Box
CFR 1/8W	52 ± 1	5 ± 0.3	75	70	255	5,000pcs
CFR 1/4WS	52 ± 1	5 ± 0.3	75	70	255	5,000pcs
CFR 1/4W	52 ± 1	5 ± 0.3	75	98	255	5,000pcs
CFR 1/2W	52 ± 1	5 ± 0.3	75	45	255	1,000pcs
CFR 1WS	52 ± 1	5 ± 0.3	86	82	255	1,000pcs
CFR 1W	64 ± 5	10 ± 0.5	94	88	255	1,000pcs
CFR 2WS	64 ± 5	10 ± 0.5	94	88	255	1,000pcs
CFR 2W	64 ± 5	10 ± 0.5	90	88	255	500pcs
CFR 3WS	64 ± 5	10 ± 0.5	90	88	255	500pcs
CPR1/2W	52 ± 1	5 ± 0.3	75	116	255	5,000pcs
CPR1W	52 ± 1	5 ± 0.3	75	45	255	1,000pcs
CPR2W	52 ± 1	5 ± 0.3	86	82	255	1,000pcs

9.2 Tapes in Reel Packing

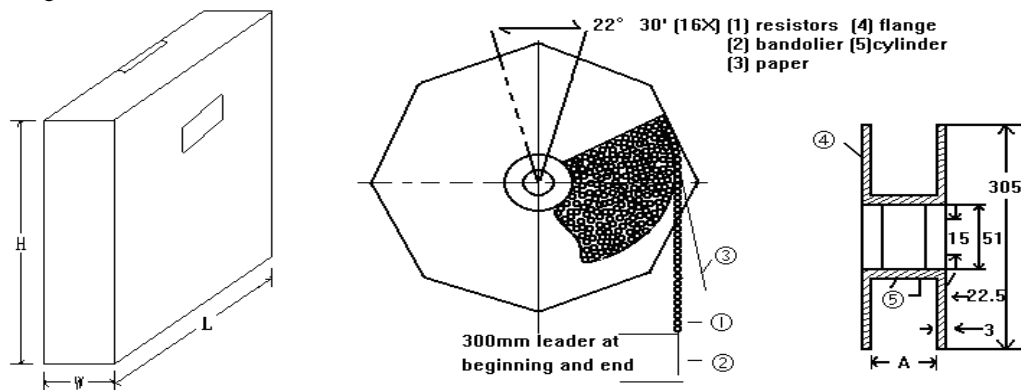

Dimension of Reel (mm)

Type	O	A	W±5	H±5	L±5	Quantity Per Reel
CFR 1/8W	52±1	73±2	85	295	293	5,000pcs
CFR 1/4WS	52±1	73±2	85	295	293	5,000pcs
CFR 1/4W	52±1	73±2	85	295	293	5,000pcs
CFR 1/2W	52±1	73±2	85	295	293	2,500pcs
CFR 1WS	52±1	73±2	85	295	293	2,500pcs
CFR 1W	64±5	80±5	95	295	293	1,000pcs
CFR 2WS	64±5	80±5	95	295	293	1,000pcs
CFR 2W	64±5	80±5	95	295	293	1,000pcs
CFR 3WS	64±5	80±5	95	295	293	1,000pcs
CPR 1/2W	52±1	73±2	85	295	293	5,000pcs
CPR 1W	52±1	73±2	85	295	293	2,500pcs
CPR 2W	52±1	73±2	85	295	293	2,500pcs

9.3 Bulk in Box Packing

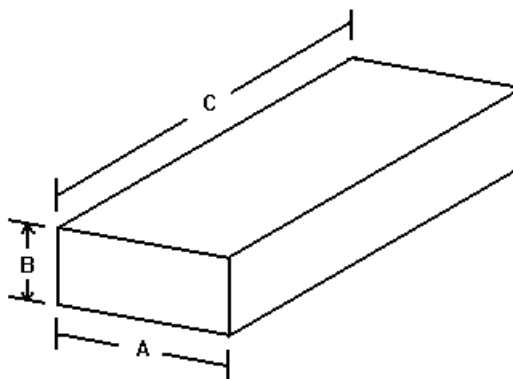

Dimension of Box (mm)

Type	A±5	B±5	C±5	Quantity Per Reel
CFR 1/8W	140	80	240	1,000/20,000pcs
CFR 1/4WS	140	80	240	1,000/20,000pcs
CFR 1/4W	140	80	240	500/10,000pcs
CFR 1/2W	140	80	240	250/5,000pcs
CFR 1WS	140	80	240	100/2,500pcs
CFR 1W	140	80	240	100/1,500pcs
CFR 2WS	140	80	240	100/1,500pcs
CFR 2W	140	80	240	100/1,000pcs
CFR 3WS	140	80	240	100/1,000pcs
CPR 1/2W	140	80	240	500/10,000pcs
CPR 1W	140	80	240	250/5,000pcs
CPR 2W	140	80	240	100/2,500pcs



10. Precaution for storage/Transportation

- 10.1. UNI-ROYAL recommend products store in warehouse with temperature between 15 to 35°C under humidity between 25 to 75%RH.
 Even under storage conditions recommended above, solder ability of products will be degraded stored over 1 year old.
- 10.2. Cartons must be placed in correct direction which indicated on carton, otherwise the reel or wire will be deformed.
- 10.3. Storage conditions as below are inappropriate:
- Stored in high electrostatic environment
 - Stored in direct sunshine, rain, snow or condensation.
 - Exposed to sea wind or corrosive gases, such as Cl₂, H₂S, NH₃, SO₂, NO₂, Br etc.

11. Record

Version	Description	Page	Date	Amended by	Checked by
1	First version	1~7	Mar.20, 2018	Haiyan Chen	Nana Chen
2	Modify characteristic	4~5	Feb.18, 2019	Haiyan Chen	Yuhua Xu
3	Modify the temperature coefficient test conditions	4	Oct.28, 2022	Haiyan Chen	Yuhua Xu

© Uniroyal Electronics Global Co., Ltd. All rights reserved. Specification herein will be changed at any time without prior notice